

ActuCOM R8

Integrated Gas Engine Speed Governor and Smart Digital Actuator

- State-of-the-art actuation and speed control for industrial engines
- Can be applied as a full-featured, self-contained gas engine speed governor or as a smart actuator
- Fully compatible with many existing alternative speed control solutions
- Incorporates a brushless motor for smooth operation and control
- Includes a configurable alarm and shutdown functions
- Features a unique, replaceable electronic “back plate” assuring simple, cost-effective on-engine service
- Configured and adjusted using a simple, no-cost terminal program
- Supports ModBus RS-485 communications as well as setpoint control from third-party devices
- Certified — Class I, Division 2, Groups C and D hazardous areas.

The Altronic ActuCOM R8 represents the next step in on-engine, integrated speed control for operators of natural gas-fueled engines. While also suitable for service as an actuation device for a third-party engine governing control system or PLC, the ActuCOM R8 can be applied as a smart actuator for virtually any appropriate engine, compressor, or pump-related function currently managed by an alternative solution, including wastegates, restrictors, and louver controls.

Housed in a robust, machined aluminum assembly, the ActuCOM R8 is built for long-term, reliable service in demanding physical environments. It is designed as a convenient, drop-in replacement for a number of competitive, integrated gas engine governor modules and associated wiring harnesses. In many

cases, simply transferring the key parameters from the existing controller to the ActuCOM R8 and plugging in the harness is often all that is required for the ActuCOM R8 to be properly setup and commissioned for service. For new installations seeking a reduced level of maintenance and/or improved control, the simple installation and configuration of the ActuCOM R8 is assured through the incorporation of a universal mounting system, an integral splined shaft, a low power consumption requirement, and the included system Terminal Program.

Whether used in the integrated speed control smart actuation functions, the ActuCOM R8 delivers new OPEX value in a cost-effective package:

- The ActuCOM R8 incorporates a brushless motor for smooth and precise control of the actuator and ultimately the speed of the engine or other process of interest.
- An innovative, replaceable backplate is integrated into the device. Embracing a similar approach used in the Altronic III and V Ignition Systems, this assembly contains all of the system electronics and can be easily replaced in the field by a technician or mechanic without a complete disassembly of the actuator from the engine.
- On-board Modbus communications allow for integration into a dedicated display or system HMI for both monitoring and control of critical ActuCOM R8 functions.
- Five (5) discrete inputs are available for control from external devices and control systems
- Integrated alarm and shutdown functionality to assure safe operation and rapid troubleshooting.

 Certified
Class I, Division 2,
Groups C and D



Specifications

Power Requirement.....	20-28VDC, 3.6 AMP
Operating Temperature	-40 to +90°C (-40 to +194°F)
Module Weight	16.0 lbs. / 7.3 kg.
Torque.....	5.9 ft/lbs. / 8 Nm
Module Mounting	Universal (T-Slots)
Actuator Shaft.....	0.625-36 Splined Serration
Actuator Position Range.....	350° of Available Travel, CW or CCW
Signal Inputs	Magnetic Pickup (Position Sensing) 4-20mA (Setpoint Control) (5) Discrete, Configurable from External Devices
Output Signals.....	(1) 4-20mA for Position Feedback
Communications	Modbus RS-485
Operational Modes.....	(2) - Speed Control, Analog Position Control

To Order

Unit, ActuCOM R8.....	691741-1
Harness, ActuCOMR8 Control, 90° Connector	
72" conduit, 120" total harness length	693215-72
180" conduit, 228" total harness length	693215-180
600" conduit, 648" total harness length.....	693215-600

Dimensions

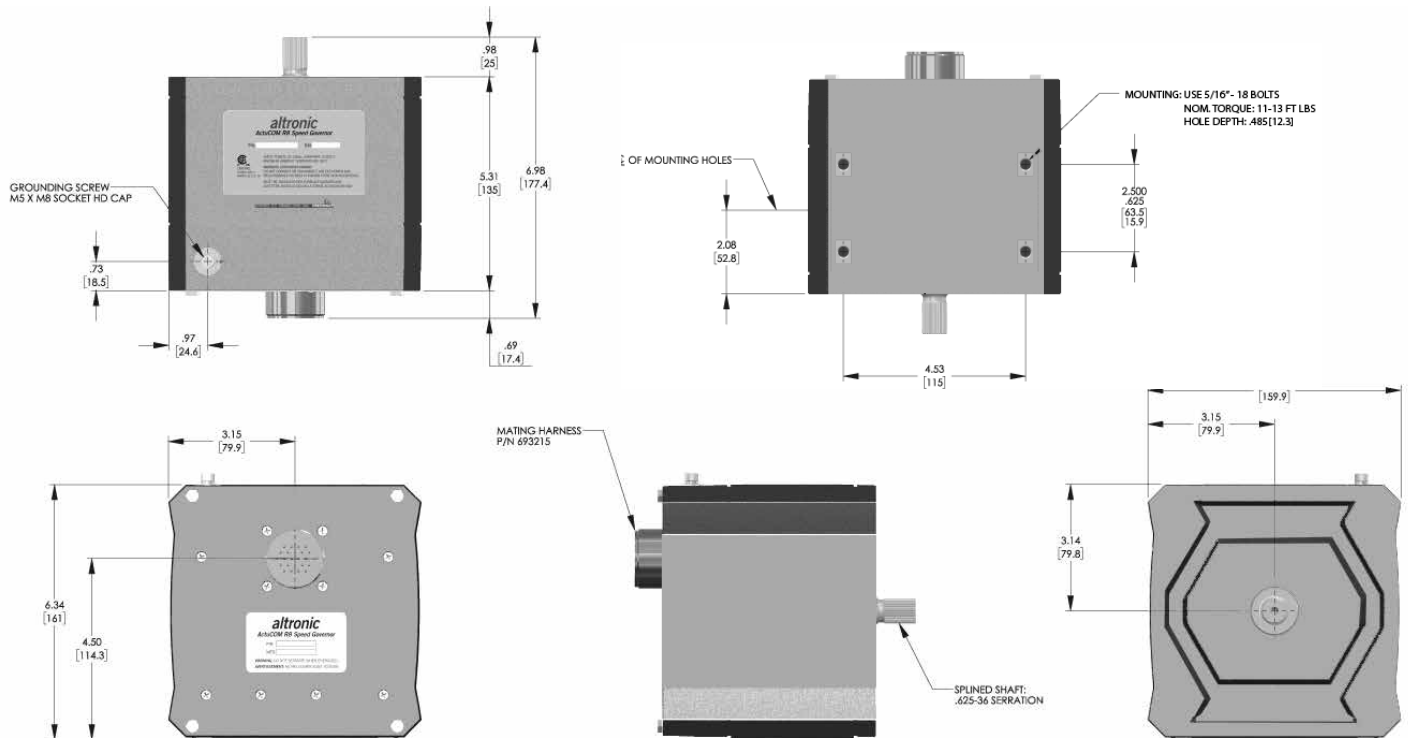

ALTRONIC

A Member of the HOERBIGER Group

712 Trumbull Avenue / Girard, Ohio 44420
 (330) 545-9768 / Fax: (330) 545-9005
 www.altronic-llc.com Email: sales@altronic-llc.com

FORM ActuCOM R8 8-22 ©2022 Altronic, LLC